



DECK DAMAGE AND PENETRATIONS

**Prepared By
Richard B. Heagler, P.E.
SDI CONSULTANT**

Copyright 1987 (Rev.2000)
All rights reserved

Steel Deck Institute

P.O. Box 25
Fox River Grove, IL 60021
Phone: (847) 458-4647
Fax: (847) 458-4648

Deck Damage and Penetrations

Damage to deck and purposeful penetrations have much in common - the location and severity are seldom known beforehand. Usually the designer knows the general area where a vent stack may cut the roof, or approximately where a telephone conduit may pierce the slab; and he may not know how big the hole will be. This lack of information makes it hard to advise how a hole should be reinforced - if at all - or how damaged deck should be repaired. Guide specifications reflect this lack of specific knowledge; the Steel Deck Institute states, "Openings not shown on the erection diagrams, such as those required for stack, conduits, plumbing, vents, etc., shall be cut (and reinforced, if necessary) by the trades requiring the openings." The designer should certainly be consulted for reinforcing requirements, but frequently, unless details are shown on the plans, no reinforcing is provided and the designer is not consulted.

Deck damage presents similar problems. Broad statements can be made such as, "All damaged deck must be replaced"; then the designer must make the decision as to what constitutes damaged deck, and he must also consider how replacement may delay the job. How much damage can be tolerated depends on architectural and structural considerations. If the underside of the deck is to be exposed to public view then very little visible damage may be allowed. In most cases, the deck will be hidden by a ceiling, or by ducts and utilities so the usual question is about structural performance.

Roof Deck

Roof Deck is designed to carry live and dead load without acting in conjunction with other materials. Horizontal as well as vertical loads may be considered.

For most 1 1/2" (38 mm) deep roof decks the loss of one rib, either by denting or penetration, can be tolerated and no reinforcement will be required. The Canadian Standard for Steel Roof Deck (CSSBI 10M-96) allows an unreinforced opening of 6" (152 mm) as long as not more than 2 webs are removed.

A simple and conservative estimate of the deck capacity would be to take out one rib (about 20% at the worst) and apply this to the uniform loads

shown in the tables; in most cases the load capacity is greater than required anyway. A six inch diameter hole will probably not bother the diaphragm strength; a dent can be larger than 6" (152 mm) and still carry the necessary horizontal load. Covering the dent or an 8" (203 mm) maximum hole with a 0.045" (1.14 mm) plate and carrying the plate to adjacent ribs could eliminate worries about insulation board spanning the dent and about a "soft spot" in the roof. For holes or dents greater than a rib (8" to 13") (203 mm to 330 mm) it would be advisable to use a 0.057" (1.45 mm) minimum plate. The following are exceptions to this advice:

- 1.) the hole may be located in such a place that the deck can safely cantilever from each adjacent support;
- 2.) a group of holes may be so close together that a frame is required.

A special case of roof penetration is the sump pan. Generally, when properly attached (see page 7) the sump pan will carry the load of the deck it replaces. It also acts as a small header to transfer loads into adjacent uncut sheets. Approximate per foot (of width) section properties of standard (0.075") (1.91 mm) sump pan are: $I = 0.36 \text{ in.}^4$ ($150 \times 10^3 \text{ mm}^4$); $S_p = 0.20 \text{ in.}^3$ ($3,277 \text{ mm}^3$). Sump pan analysis methods are shown in Appendix A, as well as a reinforcing technique.

Burn holes in side laps, caused by welded side lap attachments, are spaced far enough apart not to cause problems. However most deck manufacturers advise not welding the side laps of 0.028" (0.71 mm) deck (or thinner) because of the difficulty of obtaining a good weld. Typically, a side lap weld will cause a hole, the perimeter of the weld does the work. Burn holes near intermediate supports are unlikely to cause much loss of strength. (These holes are usually caused by the welder searching for the unseen structural member.)

Distributed small dents, such as caused by foot traffic, will not cause a structural problem; but, if the denting covers a large percentage of the job, the insulation board may be better attached with mechanical fasteners rather than by adhesives. Holes caused by mechanical fasteners or screws are not problems. If the deck is not galvanized it is good practice to paint burned or abraded areas.

Roof Deck

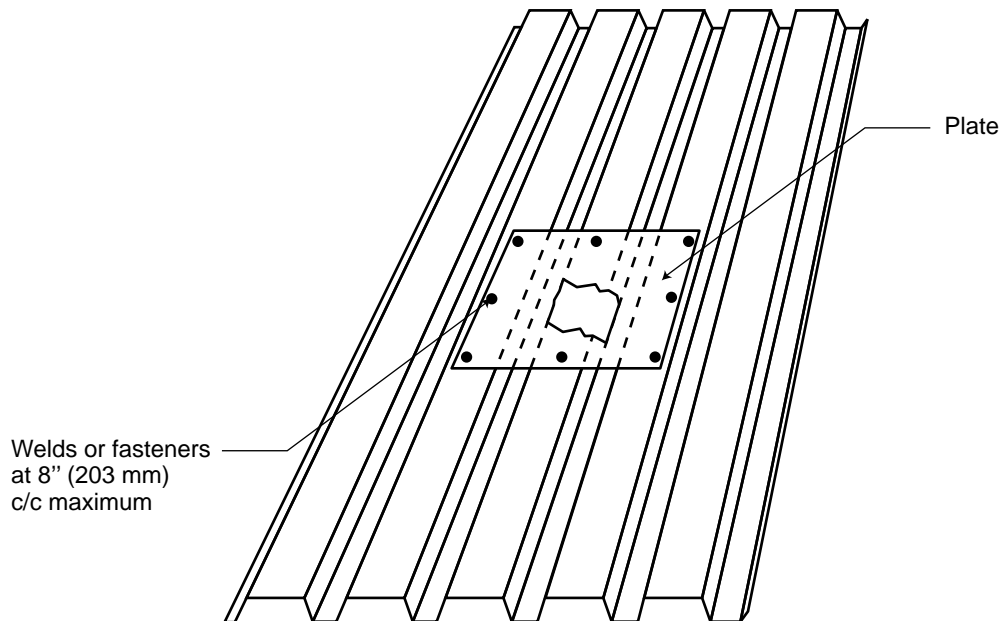

Suggested schedule:

Up to 6" (152 mm) - no reinforcing or 0.045" (1.14 mm) minimum plate thickness
6" to 8" (152 mm to 203 mm) diameter - 0.045" (1.14 mm) minimum plate thickness
8" to 13" (203 mm to 330 mm) diameter - 0.057" (1.45 mm) minimum plate thickness
Over 13" (330 mm) - frame opening* (design by project engineer)

*check cantilever ability of deck.

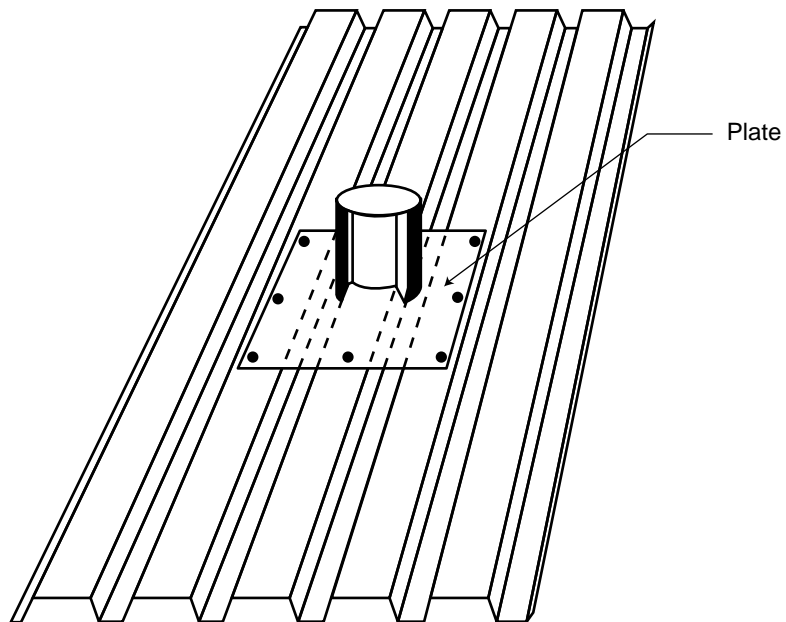

Composite Floor Deck

Floor deck serves a dual purpose - after it has done its work as a form it becomes the positive bending reinforcing for the slab. The first function, as a form, is usually more critical than the second function of carrying the live load because contractors do not like shoring the deck. Any deck damage or penetration must then be first examined as to how it affects the capacity to carry the concrete. Just as roof deck, the floor deck can be examined as a cantilever; the SDI does not publish a cantilever table for floor deck because of the great number of profile variations available.

A method for calculating allowable cantilever is shown in Appendix B. Note that if the deck is used as a cantilever, adequate top reinforcing steel must be installed. Many contractors prefer to block out concrete where a penetration will occur; and, after the concrete cures sufficiently, burn the deck away. The need for additional bars or mesh would be determined by the engineer.

Before concrete is poured the contractor shall inspect the deck to find any areas that may be damaged (crushed) and may require shoring for the pour.

FAILURE TO REPAIR OR SHORE DAMAGED DECK BEFORE THE POUR OF THE CONCRETE MAY RESULT IN INJURY.

Crushed areas or areas that buckle during the pour (usually caused by damage or by overspanning the deck) do not adversely affect the live load capacity. Tests at West Virginia University, by Dr. Larry Luttrell, showed no loss in live load capacity when the deck was purposely buckled.

The contractor should also inspect for adequate attachment at supports and side laps. Although collapsing deck failures are rare, most of them can be traced to inadequate fastening at the beams. Side laps that open during the pour are more common and are obviously caused by poor sheet to sheet connections.

Concrete provides an alkaline environment that discourages corrosion; also, most applications of composite deck are in dry interior areas and most deck is galvanized. Painting burned, cut, and abraded areas is not usually required. But, if the deck is not galvanized or the anticipated atmosphere is corrosive, then touching up damaged exposed areas is recommended.

Floor Deck

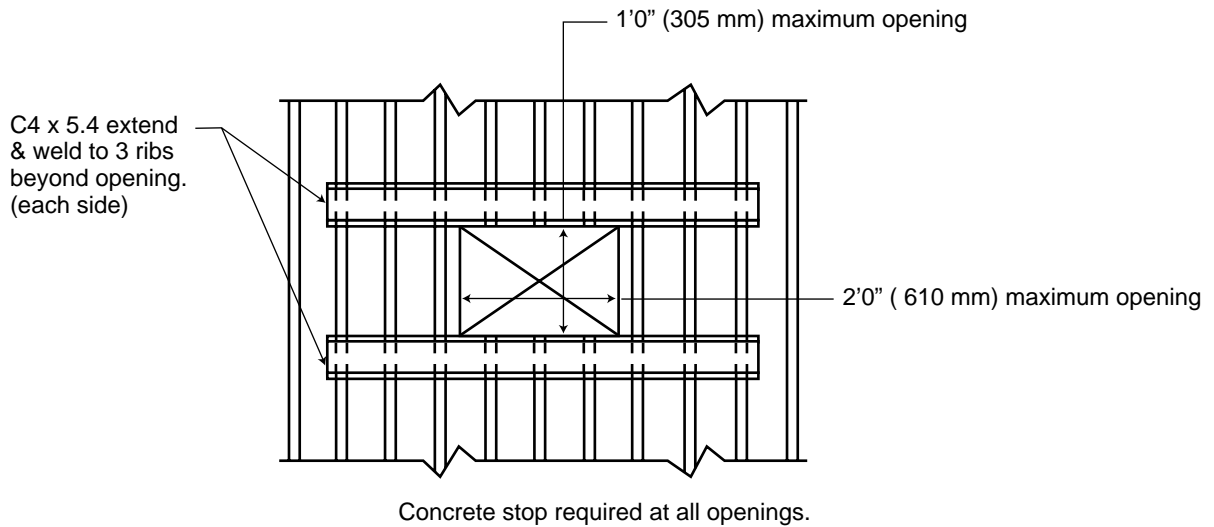

DETAIL FOR OPENINGS TO 2 ft. 0 in. (610 mm) PERPENDICULAR TO DECK

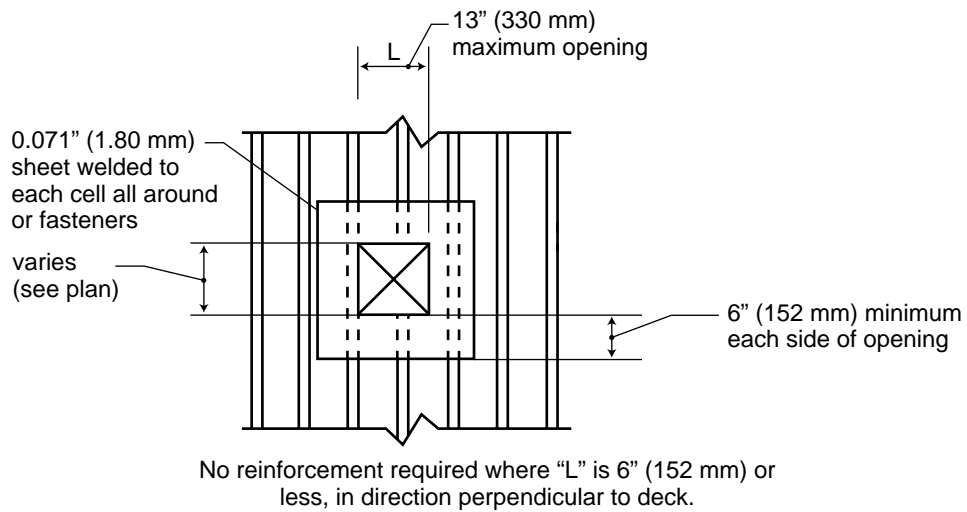

DETAIL FOR OPENINGS TO 13 in. (330 mm) PERPENDICULAR TO DECK

Appendix A

Sump Pans

Example 1: 22 gauge WR deck
 design L.L. = 40 psf (1.92 kPa)
 T.L. = 50 psf (2.39 kPa)

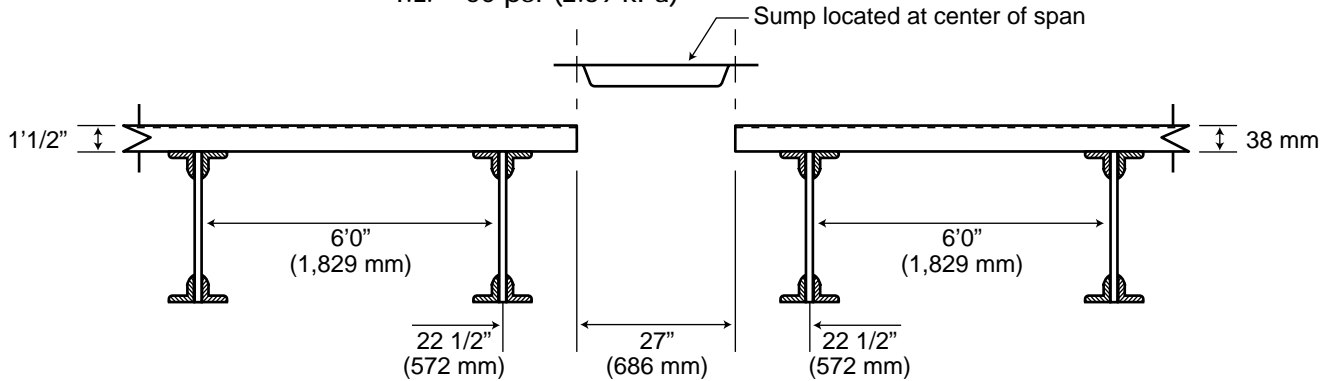

IMPERIAL

Total linear load on sump = $50 \left(\frac{27}{12} \right) = 113 \text{ lb./ft.}$

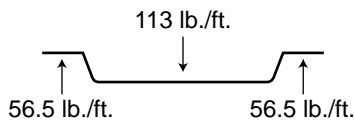

or
 construction concentrated load = 200 lb./ft.

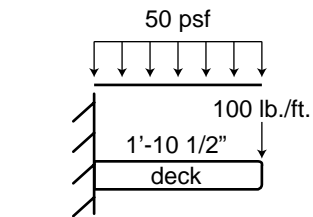
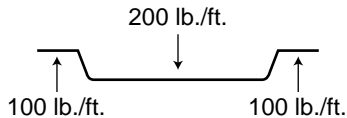

$$M = \frac{50 \left(\frac{22.5}{12} \right)^2 (12)}{2} + 100 (22.5) = 3,305 \text{ in. lb.}$$

Typical deck $s_n = 0.184 \text{ in.}^3 / \text{ft. of width}$

$$fb = \frac{3,305}{0.184} = 18,000 \text{ psi} < 20,000 \text{ O.K.}$$

$$18,000 < 26,000 \text{ O.K. (temp. man load)}$$

SI

Total linear load on sump = $2.39 \times .686 = 1.64 \text{ kN/m}$

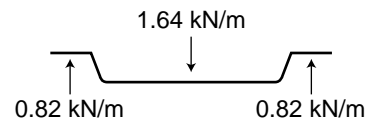

or
 construction concentrated load = 2.92 kN/m

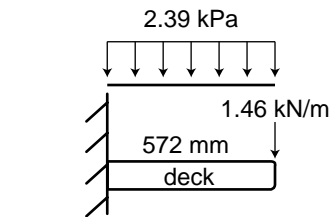
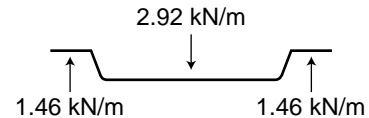

$$M = \frac{2.39 (0.572)^2}{2} + 1.46 (0.572) = 1.226 \text{ kN}\cdot\text{m}$$

Typical deck $s_n = 9,886 \text{ mm}^3 / \text{m of width}$

$$fb = \frac{1,226,000 \text{ N}\cdot\text{mm}}{9,886} = 124 \text{ MPa} < 138 \text{ O.K.}$$

$$124 < 179 \text{ O.K. (temp. man load)}$$

Appendix A

Example 1: Cantilever span of 1' 10 1/2" (572 mm) is less than the maximum recommended span for roof deck cantilever shown in the Steel Deck Institute Design Manual for WR20 deck. O.K.
No reinforcing required.

Example 2: (same dimensions as Example 1.)

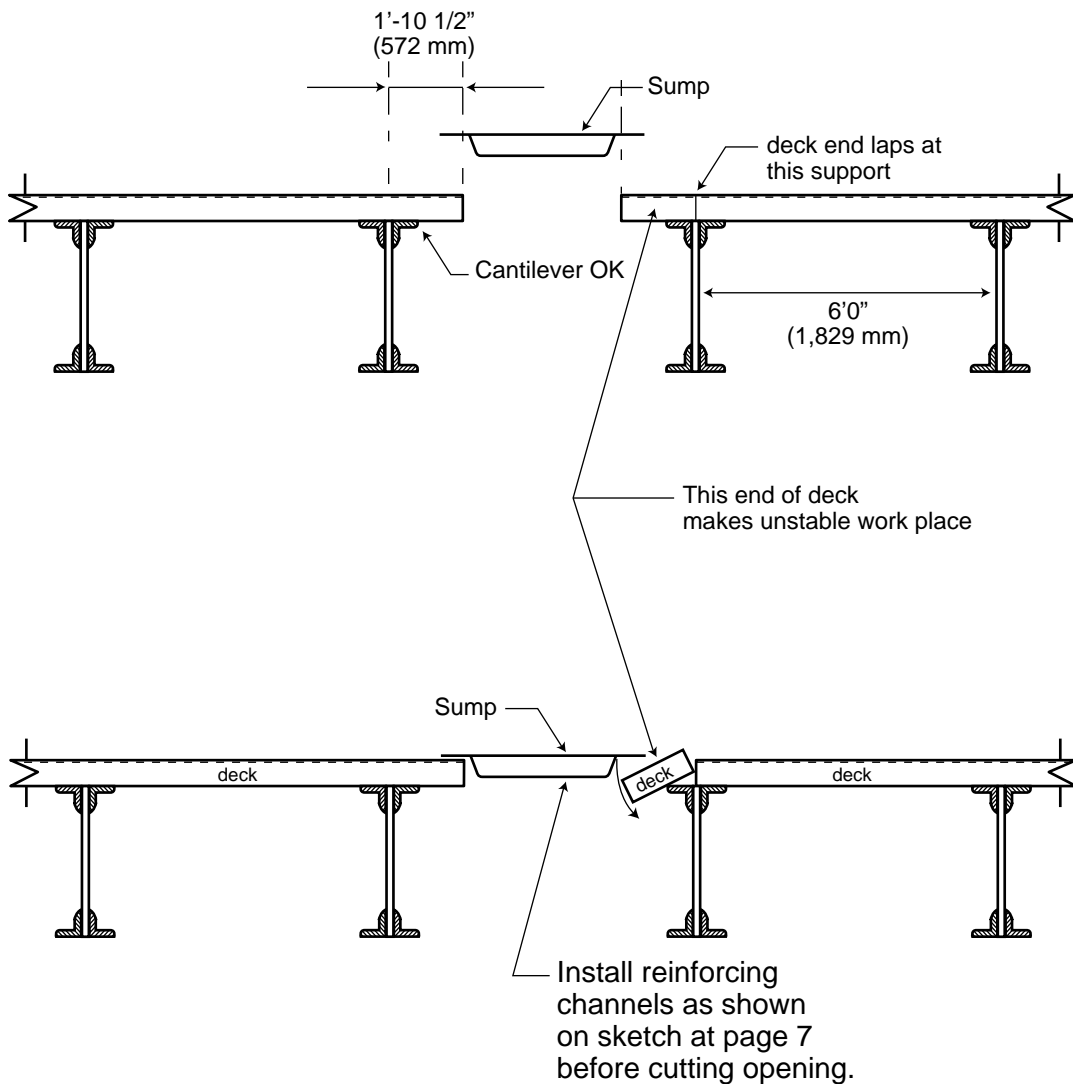

Appendix A

Roof Deck

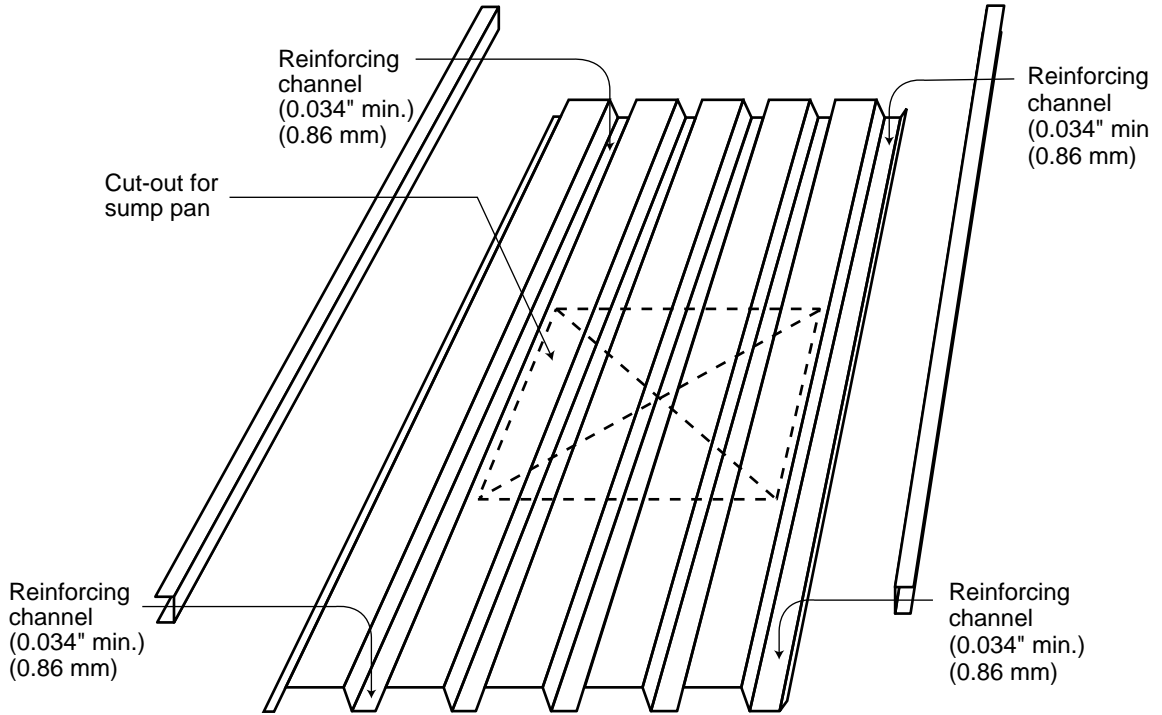

Put 1 1/2" (38 mm) deep reinforcing channels or zees in each rib at each side of opening (flush with top of deck).
Channels (zees) span between joists.
Attach flanges of sump pan to channels or Z reinforcing.

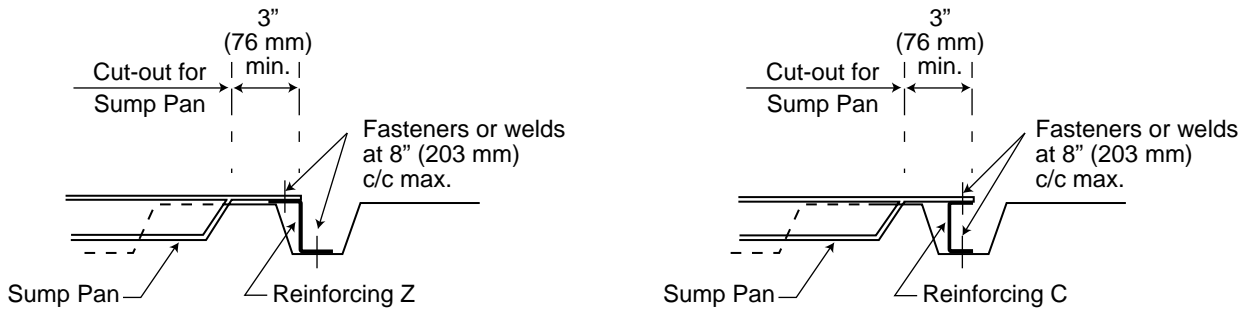

Sump pan attachment to channel or Z reinforcing

Appendix B

Maximum Floor Deck Cantilevers

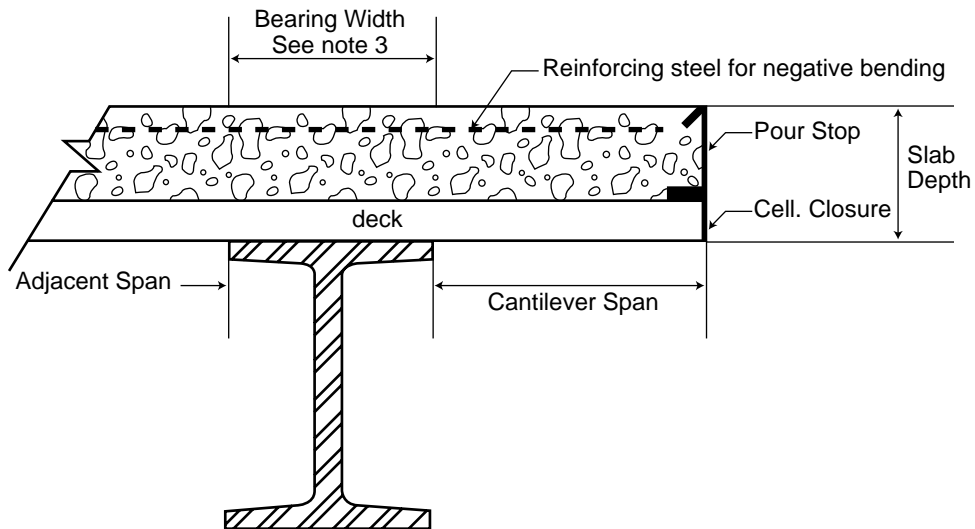

- 1.) Allowable bending stress of 20 ksi (138 MPa) with loading of concrete + deck + 20 psf (1 kPa) or concrete + deck + 150 lb. (667 N) concentrated load, whichever is worse.
- 2.) Allowable deflection of free edge (based on fixed end cantilever) of 1/120 of cantilever span under loading of concrete + deck.
- 3.) Bearing width of 3 1/2" (89 mm) assumed for web crippling check, which is; concrete + deck + 20 psf (1 kPa) over cantilever and adjacent span.